

**53024**

**SPST SOLID-STATE RELAY**

**Mii**

**HYBRID MICROELECTRONICS  
PRODUCTS DIVISION**

**Features:**

- Replacement for 690-2
- SPST, Normally Open
- 1000 V RMS Optical Isolation
- CMOS or TTL Compatible Input
- Power FET Output – Low On-state Resistance
- Full Military Temperature Operation:  
-55°C to +105°C
- Military Environmental Screening Available
- Built and Tested to MIL-PRF-28750 utilizing the test methods of MIL-STD-883C
- Qualified to 86001-001

**Applications:**

- Low level power control
- Current loop switches
- Isolated line driver
- Servo and synchro resolver control
- Military/Space general purpose switching

**DESCRIPTION**

The 53024 is a military SPST solid-state relay. This small, light-weight device is resistant to damage from shock and vibration, and immune to contact-related problems (contamination, arcing) associated with mechanical equivalents.

Optical coupling between the input and output stages provides effective isolation up to 1000 volts AC RMS. Power FET outputs eliminate bipolar offset, and minimize output voltage drop.

The control logic is TTL and CMOS compatible, and will accommodate bias supplies between 3.8 and 32 VDC. A built-in Schmitt trigger increases noise margin when using the device in the CMOS input mode.

This solid-state relay is ideal for use in military systems, or wherever high reliability, low power actuation, and light weight are design considerations. Applications include general purpose signal switching and electronic load control.

**ABSOLUTE MAXIMUM RATINGS**

Isolation Voltage ..... 1000 VAC RMS  
 Operating Temperature ..... -55°C to +105°C Case  
 Storage Temperature ..... -55°C to +125°C

**Micropac Industries** cannot assume any responsibility for any circuits shown or represent that they are free from patent infringement.  
**Micropac** reserves the right to make changes at any time in order to improve design and to supply the best product possible.

**ELECTRICAL CHARACTERISTICS**

$T_A = +25^{\circ}\text{C}$

PARAMETER	CONDITIONS	MIN	TYP	MAX	UNITS
Input (Control) Characteristics TTL Configuration					
Input Current			13	16	mA
Control Voltage Range	See Table 1 – Bias Resistance	3.8		32	VDC
Turn-Off Voltage Maximum				1.5	VDC
Turn-On Voltage Minimum		3.8			VDC
Input (Control) Characteristics CMOS Configuration					
Input Current	$V_C = +5\text{ VDC}$		25	250	$\mu\text{A}$
Control Voltage Range		2.5		18	VDC
Bias Supply - $V_C$	See Table 1 – Bias Resistance	3.8		32	VDC
Bias Current			13	16	mA
Turn-Off Voltage Minimum			2.5	2.8	VDC
Turn-On Voltage Maximum		0.5			VDC
Total Schmitt Hysteresis			1.8		VDC

**ELECTRICAL CHARACTERISTICS**

$T_A = +25^{\circ}\text{C}$

PARAMETER	CONDITIONS	53024	UNITS
Maximum Continuous Operating Output Voltage		60	VDC
Maximum Load Current	25°C	1.0	A
On Resistance – Maximum	25°C	0.35	Ohms
Typical Thermal Resistance, $\theta_{JA}$ $\theta_{JC}$		120	$^{\circ}\text{C/W}$
		30	
Turn-On Time, Maximum		3.0	ms
Turn-Off Time, Maximum		3.0	ms
Off State Leakage, 80 V		100	$\mu\text{A}$
Dielectric Strength, Minimum	I/O, 60 Hz Sine Wave	1000	V RMS
Typical Isolation Resistance	Input to Case, 500 V	$10^9$	Ohms

<p><b>Micropac Industries</b> cannot assume any responsibility for any circuits shown or represent that they are free from patent infringement.  <b>Micropac</b> reserves the right to make changes at any time in order to improve design and to supply the best product possible.</p>
---

**Package Dimensions**

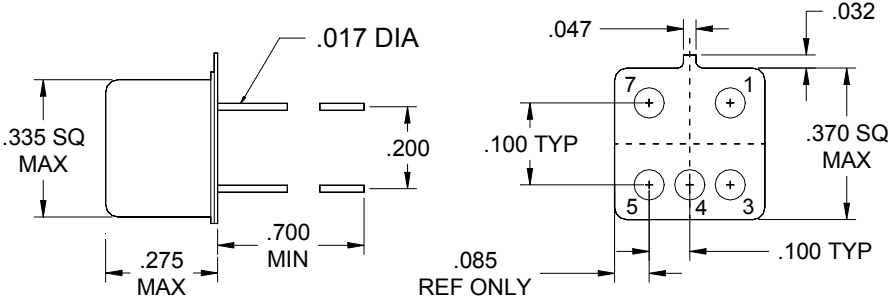

**Application Information**

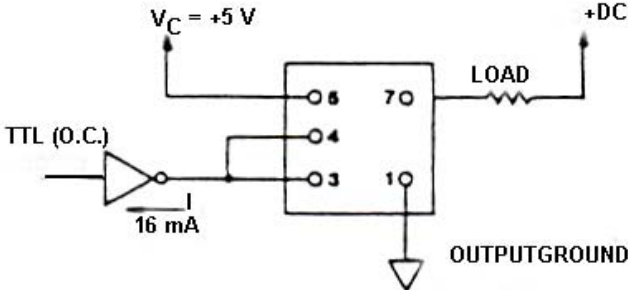

TTL CONFIGURATION  
(NON-INVERTING)

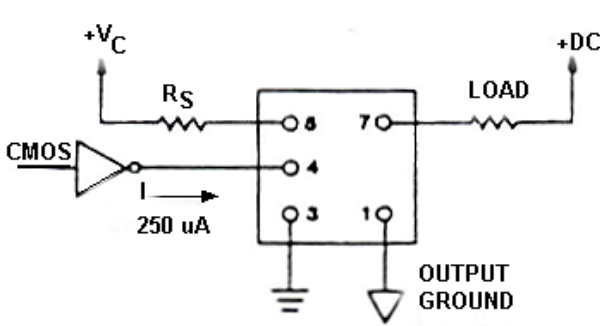

CMOS CONFIGURATION  
(INVERTING)

**Table 1**  
**Limiting Resistance (Rs) Values**  
**(With Heat Sink)**

V(VDC)	3.8-6	6-10	10-14	14-18	18-22	22-26	26-32
R(Ω)		300	620	910	1200	1500	2000
Rating (W)		¼	¼	½	½	½	1

Micropac Industries cannot assume any responsibility for any circuits shown or represent that they are free from patent infringement. Micropac reserves the right to make changes at any time in order to improve design and to supply the best product possible.